

MODEL	SPECIFICATION 製品規格書	文件編號： Q-21CSG1811002-01
		版本版次：V1
		頁 次： 1/3

1. 使用環境條件

Apply Environmental Condition :

No.	Item	Specification
1-1	保存溫度 Storage Temperature Range	-20℃～60℃
1-2	操作溫度 Operating Temperature Range	-10℃～50℃
1-3	操作電壓 Operating Voltage Range	4.8V～7.4V

2. 測試環境

Standard Test Environment :

2-1	測試環境 Standard Test Environment	Every characteristic of the inspect must be normal temperature and humidity carry out the test , temperature 25±5℃ and relative humidity 65±10% of judgment made in accordance with this specification standard testing conditions.
-----	-----------------------------------	---

3. 外觀檢查

Appearance Inspection :

No.	Item	Specification
3-1	外觀尺寸 Outline Drawing	Dimension see the attachment
3-2	外觀 Appearance	No damage which affects functions allowed

	Product Name SERVO	Model No. SV-1270TG
---	------------------------------	-------------------------------

MODEL	SPECIFICATION 製品規格書	文件編號: Q-21CSG1811002-01
		版本版次: V1
		頁 次: 2/3

4. 電氣特性

Electrical Specification (Function of the Performance) :

No.	Item	6.0V	7.4V
4-1	空載轉速 Operating speed (at no load)	0.14 sec/60°	0.11 sec/60°
4-2	空載電流 Running current (at no load)	120 mA	150 mA
4-3	停止扭力 Stall torque (at locked)	26.0 kg-cm	35.0 kg-cm
4-4	停止電流 Stall current (at locked)	5500 mA	6800 mA
4-5	待機電流 Idle current (at stopped)	5 mA	5 mA

Note: Item 4-2 definition is average value when the servo running with no load

5. 機械特性

Mechanical Specification :

No.	Item	Specification
5-1	外觀尺寸 Overall Dimensions	See the drawing
5-2	機構極限角度 Limit angle	200°±10°
5-3	重量 Weight	64.0 ± 1 grams (without servo horn)
5-4	導線規格 Connector wire gauge	# 22 AWG
5-5	導線長度 Connector wire length	200 ±5 mm
5-6	舵片規格 Horn gear spline	φ 6* φ 5.2*25T
5-7	舵片種類 Horn type	Cross , Disk , Star

	Product Name SERVO	Model No. SV-1270TG
---	------------------------------	-------------------------------

MODEL	SPECIFICATION	文件編號: Q-21CSG1811002-01
	製品規格書	版本版次: V1
		頁次: 3/3

6. 控制特性

Control Specification :

No.	Item	Specification
6-1	控制系統 Control system	Pulse width modification
6-2	放大器種類 Amplifier type	Digital Controller
6-3	操作角度 Operating travel	100° (when 1000→2000 μsec)
6-4	中立位置 Neutral position	1500 μsec
6-5	脈波訊號虛位 Dead band width	3 ~ 5 μsec
6-6	旋轉方向 Rotating direction	Counterclockwise (when 1000→2000 μsec)
6-7	脈波寬度範圍 Pulse width range	800→2200 μsec
6-8	可作動角度範圍 Maximum travel	Approx 130° (when 900→2100 μsec)

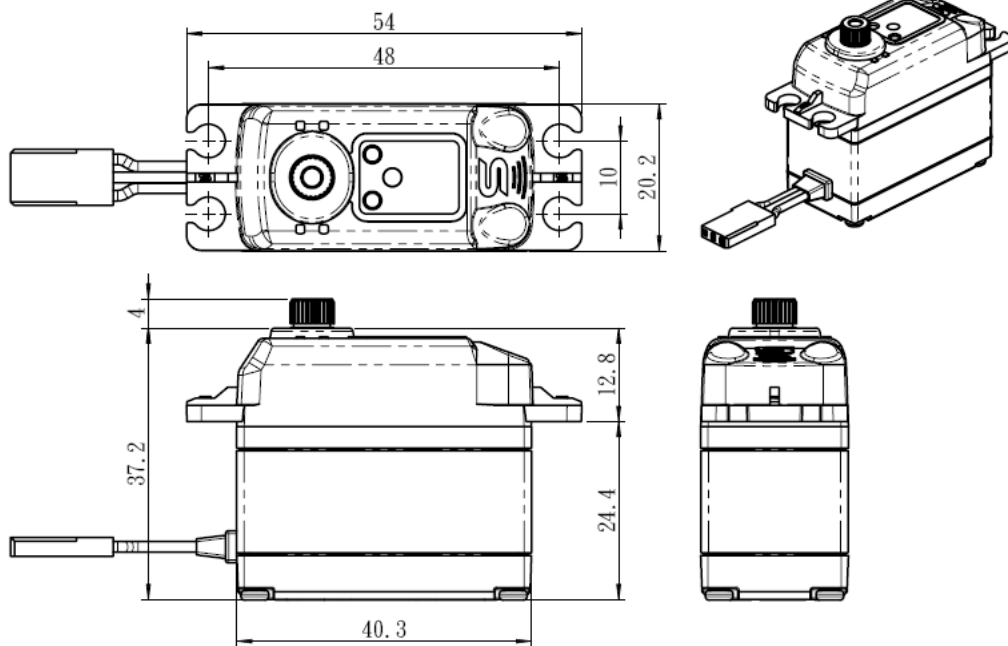

	Product Name SERVO	Model No. SV-1270TG
---	------------------------------	-------------------------------